

TRUCKS AND BUSES



STAY AHEAD

Eicher Pro 3015

The 16 Tonne GVW Truck



Mileage ka Badshah

EUTECH 6



EUTECH 6

Eicher is creating a new benchmark in the Indian commercial vehicle industry, through a revolutionary BSVI solution that combines global technology with innovative support services. This solution not only makes your vehicle BSVI compliant but also ensures higher productivity of the truck and profitability of your business.



Euro VI Expertise for 6 years

VECV has been manufacturing and supplying base engines to the Volvo Group since 2013. Over 1,00,000 Euro VI base engines supplied, operating in 41 countries. First to roll out BSVI CV range in India, incorporating expertise of Euro VI technology.



Efficient EATS and engine technology

Best fluid economy: Lower fuel consumption + DEF consumption combined. Reliable EATS + engine technology tested for over 56,00,000 km. Duty cycle based SCR for high reliability & low maintenance.



Enhanced UPTIME

Eicher Uptime Centre for 24x7 support by specialists. GPS enabled service vans just a phone call away. Remote diagnostics for quick repair of BSVI vehicles.

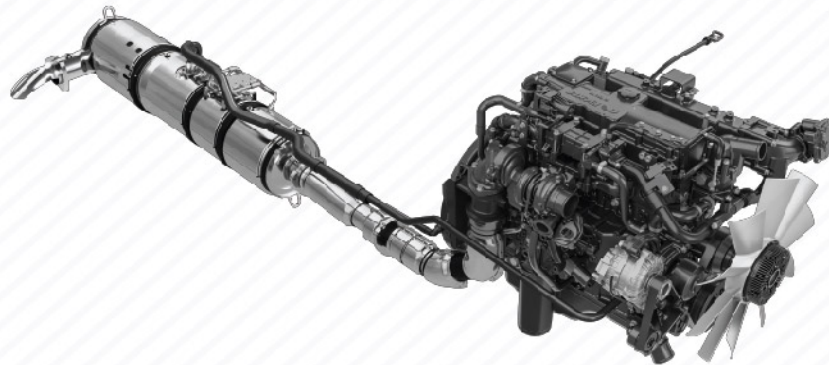

FUEL EFFICIENT E494 4 CYLINDER, 4 VALVE, 3.8 LITRE CRS ENGINE



Redefining levels of performance & profitability to stay ahead in business with Eicher Pro 3015 with next-generation E494 engine & 7 speed gearbox. Its revolutionary driver comfort, cutting edge technology, best in class safety and reliability along with superior overall performance keep you "Stay Ahead"





Stay Ahead with Best-in-class Mileage

- 1 » Next-generation E-494 Engine with India's First 7 Speed Gear Box.
- 2 » M Booster+ helps to save fuel on different payload selections with Power, Eco and Eco+ mode.
- 3 » Smart Fuel Coaching along with Dynamic Green band Zones is a Driver's real time coach.
- 4 » Cruise Control provides a fatigue free driving experience.



Stay Ahead with Best-in-Class Comfort

- 1 » 2.1m wider cockpit designed fully trimmed sleeper cabin.
- 2 » Mechanical Suspended seats.
- 3 » Front Parabolic suspension for better ride comfort.
- 4 » Music system and Proper utility spaces.



Stay Ahead with safest and most Reliable Truck

- 1 » Enhanced safety with Double panel cabin and Heavy Duty Bumper.
- 2 » Antiroll bar for safer turns on sharp turn roads.
- 3 » Stronger and rugged Domex chassis.
- 4 » Monotron propeller shaft with life time maintenance free.

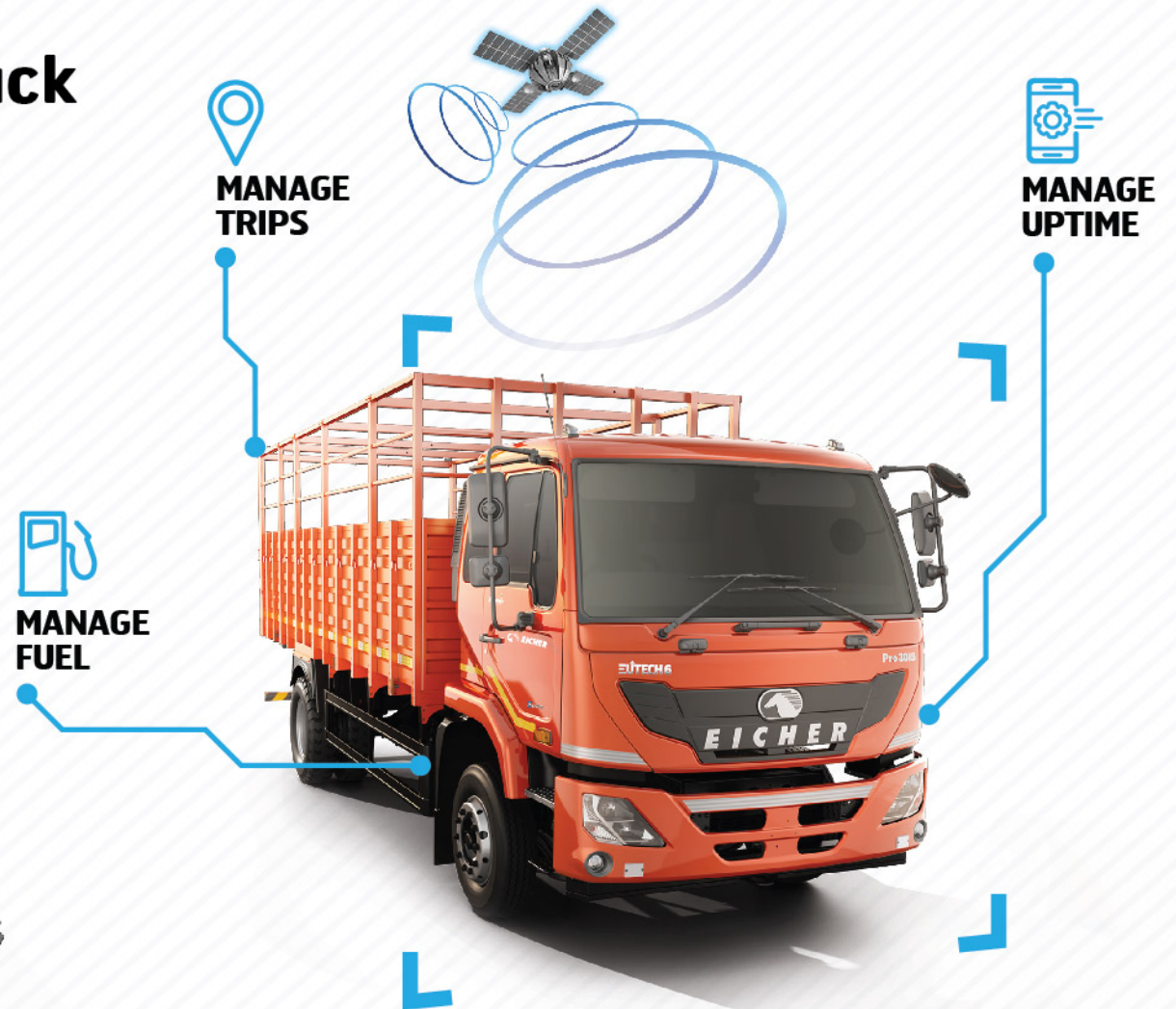
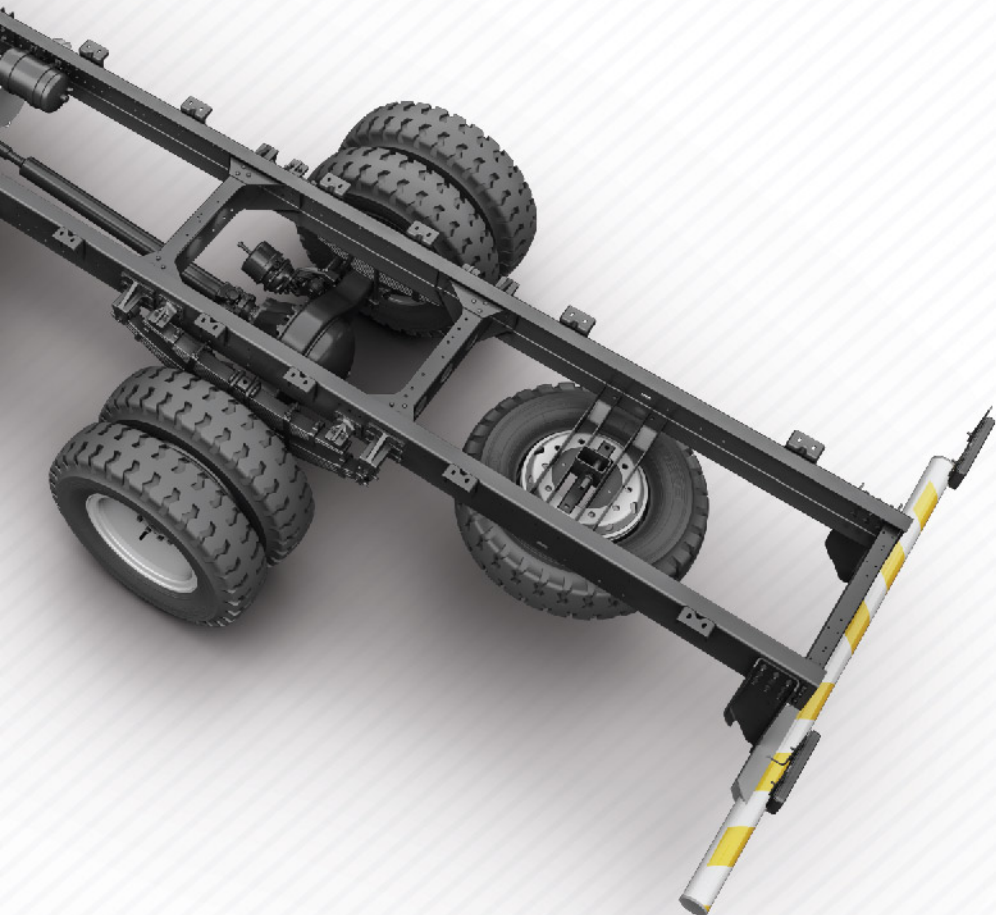

Stay Ahead with Eicher Live Telematics

Remain 24X7 connected with your Truck with just a touch of an App

- 1 » Manage Trips – Track & Trace Features, Geofencing, Fleet level Reports.
- 2 » Manage Fuel – Real Time Fuel status, Monitor idling and harsh usage.
- 3 » Manage Uptime – Fault prediction and Alerts for Service, Insurance and Fitness.

Lifetime Support Solutions.

With our Lifetime Support Solutions, we ensure a seamless and hassle-free experience from the time you consider buying an Eicher vehicle to the time you think of selling it. Our continuously improving and holistic services will ensure higher uptime and productivity for your BSVI vehicles.

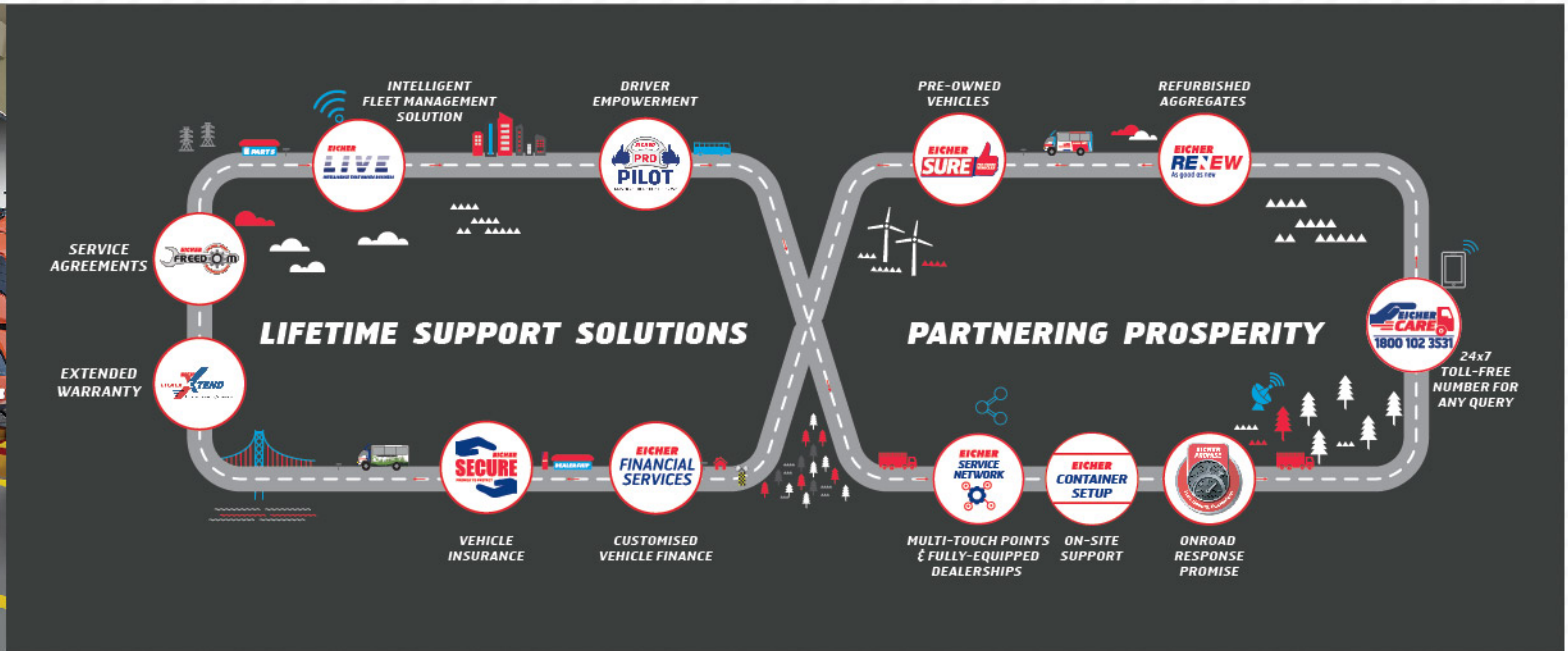

Eicher has taken a step towards achieving Superior Uptime with a responsive attitude, that will set us apart and create a differentiated experience for our customers. With our new Uptime Center and Uptime Certified Workshops, we are now geared up with a proactive support system for diagnostic assistance with advanced diagnostic tools.



SPECIFICATIONS

Eicher Pro3015

GVW (kg)	16020			
Wheelbase (mm)	4490	5490		
Length (mm)	5811	6112	6782	7364
Width (mm)	2287			
Engine	E494 4V TCI BS VI (CRS Diesel Engine)			
Max. power output	160 hp @ 2600 rpm			
Max. torque output	500 Nm @ 1200-1800 rpm			
Emission	BS VI			
Fuel Type	Diesel			
Transmission	ET50S7			
Gear Type	7 Speed: 7 F (2 overdrive gears) + 1 R			
Clutch Dia (mm)	330			
Gradeability (%)	23			
Steering	Tilt and telescopic Standard Power Steering			
Turning Circle Diameter (m)	17.5	21.6		
Ground Clearance (mm)	258			
Battery	12 V-100 AH			
Fuel Tank Capacity	Anti-Corrosive Composite HDPE Polymer-190 Ltrs 425 Ltrs			
Brakes (Service)	Air Brake (Drum)			
Suspension	Front-Parabolic with shock absorber Rear-Semi elliptical laminated leaves with helper spring			
Tyre Size	9.00R20-16PR Standard Radial Tyres			
Cabin	2.1 m cockpit design sleeper cabin			



VE COMMERCIAL VEHICLES
A VOLVO GROUP AND EICHER MOTORS JOINT VENTURE
eichertrucksandbuses.com, Eicher Care: 1800 102 3531

VE COMMERCIAL VEHICLES LTD.
Registered Address – 3rd Floor Select Citywalk,
A -3 District Centre, Saket, New Delhi 110 107, India.
CIN – U74900DL2008PLC175032

Applications.



Fruits & Vegetables



Cement



Fish



Industrial components



FMCG



White goods



Beverages



Parcel & Courier



Food & Grains

CORPORATE ADDRESS
Eicher Trucks & Buses
#96, Sector – 32, Gurgaon
122001, Haryana, India.

Caution: *Do not weld or drill on chassis frame. *Accessories and features shown in pictures or elsewhere may not constitute standard fitment. *Weight mentioned is for standard configuration with standard body sizes and will change due to optional fitments. *As a result of continuous research and innovation carried out, specifications are merely indicative and are subject to change without notice.